

Flood Preparedness and Response

Like a fire engine, the trailer-mounted sandbagging machine can be deployed quickly, arriving on the scene ready to fill and deploy sandbags where they are needed most. An optional electric generator can provide on-board power even at remote jobsites.

High output, portability, and reliability make Mr. Sandman™ the ideal choice for flood preparedness and response.

Special Government Financing

Mr. Sandman™ offers special financing for government agencies. Up to 100% of equipment costs may be financed, including training and maintenance fees. Lease-Purchase financing allows government agencies to get the equipment they need immediately. Municipal leases include a non-appropriation clause that allows lease termination if funds are not available in subsequent fiscal years.

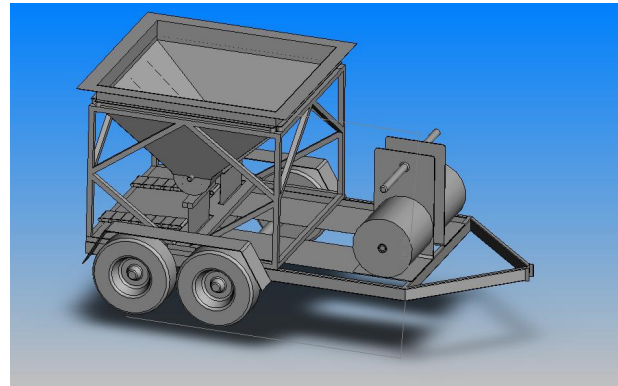

The Machine

Mr. Sandman™ is mounted on a heavy-duty trailer with electric brakes. The machine can be towed behind a standard pickup truck to drop bags right where they are needed. Operates on shore power or with optional generators available in gas, propane, or diesel.

- **High Volume Output**
- **Reliable**
- **Fully-automated**
- **Affordable**
- **Heavy-Duty**
- **Portable**

M r . S a n d m a n ™

**1735 Reliez Valley Road
Lafayette, CA 94549
USA**

**Phone: (925) 639-4894
Email: gint@gfederas.com**

**The First (and only)
Fully-Automated
Sandbagging Machine**

Mr. Sandman™



Flood
Preparedness
And Response

Construction

Military

Fully-Automated Sandbagging

Sandbags have been filled the same way for decades, by hand. This time-consuming, labor intensive, back-breaking process turns highly productive workers into unskilled laborers. That is, until now.



Mr. Sandman™ patented the first (and only) fully-automated sandbagging machine. At over 1,000 sandbags per hour, this machine replaces 24 manual laborers with 1 operator.

No more lost productivity. One machine frees up dozens of workers, reducing labor costs, payroll taxes, benefits, health insurance, workmen's compensation insurance, etc. Also, machines don't take holidays or call in sick.

Filled Sandbags

Mr. Sandman™ also sells filled sandbags to meet your preparedness needs. Sandbags are palletized and shipped by truck. Place orders well in advance of need, as shipping may be delayed due to inclement weather. Minimum order—10,000 bags. Competitive pricing.



Flood Preparedness and Response / Construction / Military

Flood Preparedness and Response

Too often, flood preparedness is put off to the last minute. No wonder. With the cost of labor, health insurance, workmen's compensation, etc. municipalities and businesses can hardly afford to divert their workers to fill sandbags "just in case".

Filling sandbags is something you do when volunteers line up by the hundreds to protect their homes and property. In a flood emergency, human resources include trained specialists who are focused on repairing utility services or protecting property. Would you rather have trained experts filling sandbags or restoring electric, water, and phone services?

Productivity Improvement

A team of two men - one with a shovel, the other holding and closing the bag - can fill about 90 bags per hour. Hence, 24 men could fill 1,080 bags per hour. Add to that another 2-3 people to stack sandbags or load the completed sandbags onto a palette or truck. For comparison, it takes 1,000 sandbags, properly stacked, to cover an area 120ft. long by 2ft. high. (For a dike, 2' x 50' = 1,100 sandbags) In other words, it takes at least 24 people x 1 hour to fill and stack enough sandbags to protect just one house or business during a flood. How many people will it take to protect large areas in the case of fast-rising flood waters?

Mr. Sandman™ is the answer. Using just 1 machine operator (instead of 24 laborers), Mr. Sandman™ fills, seals, and discharges over 1,000 sandbags per hour.

Military Applications

Deploying military reserves overseas removes the "safety net" provided by the National Guard during domestic emergencies. Also, military manpower is stretched rather thin overseas. Filling sandbags is a critical task for protective cover. Short-handed military organizations both domestically and abroad need Mr. Sandman™ to free up manpower for other security tasks.



The Process

Mr. Sandman™ cuts polypropylene bags from a roll and fills each one with about 50 lbs. of sand, seals, and discharges finished bags to the rear. There are two independent filling stations, allowing one side to run continuously while replacing bag rolls on the other side. The machine is mounted on a heavy-duty trailer, so it can be towed while operating—dropping bags where they are needed most.

Mr. Sandman™

1735 Reliez Valley Road
Lafayette, CA 94549
USA

Phone: (925) 639-4894
Email: gint@gfederas.com

Contact: Gint Federas